

WAVEFORM

# OmniRoam

Omni-Directional Mobile Antenna

## PLEASE READ THIS FIRST:

We know, reading manuals isn't always fun. But we promise it's worth it.

We've helped thousands of customers improve their connectivity on the go, and we've compiled everything we've learned in this manual.

Give it a read before you start: it'll save you time and help you get the best performance out of your OmniRoam.

## Designed by WAVEFORM in the USA

Your OmniRoam is designed, sold, and supported by Waveform and our team of Signal Specialists.

We've helped over 50,000 customers improve their signal since the company was founded in 2007.

If you have any issues at all, **please reach out.**



3411 W. Lake Center Dr.,  
Santa Ana, CA 92704



+1 (800) 761-3041



[www.waveform.com](http://www.waveform.com)  
[help@waveform.com](mailto:help@waveform.com)

# What's in the Box

## OmniRoam Antenna & Mounting Plates



OmniRoam Antenna  
*with 2-9 cables, by configuration*

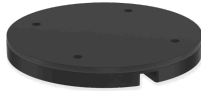

Magnetic Mount  
*for most roofs*

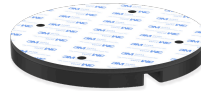

Adhesive Mount  
*for non-metal roofs*

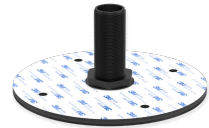

Spigot Mount  
*for drilled mounting*

## Accessories



5x Bolts  
*for mounting plates,  
1x spare included*



2.5mm Allen Wrench  
*for bolts*



5x Velcro Ties  
*for cable management*

## Optional Cables & Adapters

Depending on the add-ons you've selected, you may also have some of the following:



SMA-Female to Male  
Extension Cables  
*for extending Cellular & GPS  
cables, quantity varies by kit*



RP-SMA-Female to Male  
Extension Cables  
*for extending Wi-Fi cables,  
quantity varies by kit*

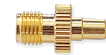

SMA-Female to TS9  
Adapters



SMA-Female to FAKRA Z  
Adapters



# 00 Before You Start

OmniRoam will help your router stay connected to cell service, GPS and WiFi even on the very edge of coverage, where your router would lose connection by itself.

However, **even OmniRoam needs some signal to work**, so when you have no service whatsoever, OmniRoam probably won't be able to create or maintain a connection.

## What Do We Mean by "No Service"?

Simply put, if you step outside of your vehicle, and **your phone shows "No Service" instead of bars**, or if your phone doesn't even pick up the WiFi network, OmniRoam will probably struggle too.

If your OmniRoam has a GPS antenna however, you'll stay connected to GPS as long as it has a view of the sky, even if it's partially obstructed.

While it still needs some signal to connect, OmniRoam will to **keep you online in areas where your router alone would lose connection**, especially when moving between zones of weak coverage.

## What Performance Should You Expect?

OmniRoam is all about **staying connected and maintaining a reliable connection** at the edge of coverage where your router alone would otherwise lose signal. The results you'll can vary, especially when traveling through areas with very strong or no cell service:



- **No service?:** In areas with no service, OmniRoam can't create a connection; be it to 5G, WiFi or GPS.
- **On the edge of coverage?:** OmniRoam excels when you're in areas with weak or fluctuating signals, allowing you to stay connected when your router alone would lose signal.
- **In a strong signal area?:** In areas with good signal, you may not notice a significant boost in performance compared to your cellular router by itself. OmniRoam's primary function is to help you stay connected in weaker coverage areas.



Once you've installed your OmniRoam, if you aren't seeing the performance you expect, **please reach out to us for help.**



## Cellular Compatibility

Your OmniRoam supports almost every 4G LTE and low/mid-band 5G service in use in the US, Canada, and across the world. Here are the bands that it covers\*:

USA	 <b>AT&amp;T</b>	B2/n2, B4, B5/n5, B12, B17, B29, B30, B46, B66/n66, n77
	 <b>verizon</b>	B2/n2, B4, B5/n5, B13, B46, B48/n48, B66/n66, n77
	 <b>T-Mobile</b>	B2, B4, B5, B12, B25, B26, B41/n41, B46, B66, B71/n71, n77

CANADA	 <b>Bell</b>	B2, B4, B5, B7, B12, B13, B17, B29, B46, B66/n66, B71, n78
	 <b>ROGERS</b>	B2, B4, B5, B7, B12, B17, B25, n41, B66/n66, n71, n78
	 <b>TELUS</b>	B2, B4, B5, B7, B12, B13, B17, B25, B26, B29, B46, B66/n66, B71/n71, n78

**All supported 4G (LTE) Bands:** B1, B2, B3, B4, B5, B7, B8, B11, B12, B13, B14, B17, B18, B19, B20, B21, B22, B25, B26, B28, B29, B30, B32, B34, B37, B38, B39, B40, B41, B42, B43, B46, B47, B48, B50, B51, B53, B65, B66, B67, B69, B70, B71, B74, B75, B76, B85, B103, B106

**All supported 5G (NR) Bands:** n1, n2, n3, n5, n7, n8, n12, n13, n14, n18, n20, n25, n26, n28, n29, n30, n34, n38, n39, n40, n41, n46, n47, n48, n50, n51, n53, n65, n66, n67, n70, n71, n74, n75, n76, n77, n78, n79, n80, n81, n82, n83, n84, n85, n86, n89, n90, n91, n92, n93, n94, n95, n96, n97, n98, n99, n100, n101, n102, n105

## Wi-Fi Compatibility

If your OmniRoam includes Wi-Fi antennas, you'll be able to **enjoy the full spectrum of Wi-Fi 7.**

Wi-Fi	 <b>Wi-Fi 7</b>	2.4 GHz, 5 GHz, 6 GHz
-------	--	-----------------------

## GPS Compatibility

If your OmniRoam includes a GPS antenna, it's GPS antenna **supports multiple GPS bands.**

GPS	 <b>GPS</b>	Band L1
	 <b>GALILEO</b>	Band E1
	 <b>GNSS</b>	Band G1



## 02 Plan Your Setup

### Choosing Your Mount

Your OmniRoam offers **three mounting options**: magnetic, adhesive, and spigot. Each option has its own advantages depending on your needs and vehicle setup.

- » **Magnetic Mount:** We think the magnetic mount is probably the **best option for most people**, as long as your vehicle has a metal roof. It's quick and easy to setup, and the nine neodymium magnets guarantee your OmniRoam isn't going anywhere.
- » **Adhesive Mount:** If your vehicle doesn't have a metal roof, the adhesive mount will do the trick. It includes a very strong one-time-use adhesive for a secure hold.
- » **Spigot Mount:** For permanent installs, or vehicles with limited cable entry points, the spigot mount is ideal. Just make sure the mounting surface is **no thicker than 7.0 cm (2.75 in)** and **clear of any obstructions** like cables, b-pillars, and structural elements.

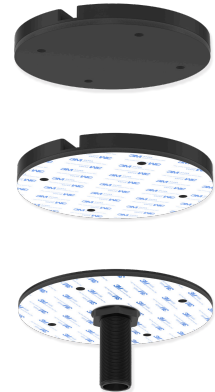

### Picking the Best Spot for Your OmniRoam

For a secure installation and good performance, we suggest picking a mounting location that **meets all the following criteria**:

- Is on the **roof or the highest point** of the vehicle, with **no obstructions within an arms reach**.
- Is a **flat and stable** surface, at least 20 x 20 cm (8 x 8 in) in size. If your vehicle's roof has ridges or bumps, position the antenna between them or at their edges.
- Is at least 50 cm (20 in) from **heat sources**, like exhaust pipes.
- **Allows the cables to reach your router**. If you need a longer cable to reach your router, we offer cable extensions at [waveform.com/omniroam-cable](http://waveform.com/omniroam-cable).

If you're installing OmniRoam on a car, SUV or van, **the best spot is likely in the middle of the roof toward the rear of the vehicle**, so that you can easily run the cables through the rear door.

# Planning Your Cable Path

Routing the cables from OmniRoam into your vehicle and to your router is often the most time-consuming part of the installation.

While every vehicle is so different that we can't reasonably tell you exactly how to go about it, we have some recommendations that should be helpful.

1. **Through the trunk or rear door.** In most cases we recommend setting up your router in the trunk, and running OmniRoam's cables directly through the rear door, where they're out of the way and easy to manage.
2. **Through the side doors.** If the trunk won't work, it's often quite easy to feed the cable through an upper corner of one of the passenger doors
3. **Conduits and gommets.** Larger vehicles like RVs and semi trucks tend to have dedicated cable channels from their roofs for exactly this purpose.

When planning your cable path, keep these best practice in mind:

- **Avoid sharp bends, kinks, or twists** that could damage your OmniRoam's cables. Keep bends at a radius of at least 1.5 cm (0.6 in).
- **Avoid sharp edges** that might wear down the cable over time.
- **Cable manage your cables** with zip ties to keep them safe and out of the way. If you're entering through a door, spread the cables out and tuck them under the door seal.
- Protect connections from the elements by waterproofing any outdoor connections with silicone weatherproofing tape or waterproof connector boots.
- When pulling your cables, always pull on the cable jacket and never on the connectors to prevent damage.

## We're Here to Help!

We know that installing an antenna to any vehicle can be challenging, and that every installation is unique. **We can help!** If you're running into issues, or have any questions, please reach out.

Call us at **(800) 761-3041**, email [help@waveform.com](mailto:help@waveform.com), or book a meeting at [waveform.com/meet](https://waveform.com/meet) to **chat with a dedicated Waveform Signal Specialist**. We're available from 9am- 5pm PT, Monday to Friday.





# 03 Installing Your OmniRoam

Now that you've found a good spot to mount your OmniRoam, **it's time to install!** Follow the steps below for the mount you've picked, and let us know if you have any questions.

## Option 1 **Magnetic Mount**

If your vehicle has a metal roof, the magnetic mount is our top pick for mounting your OmniRoam:

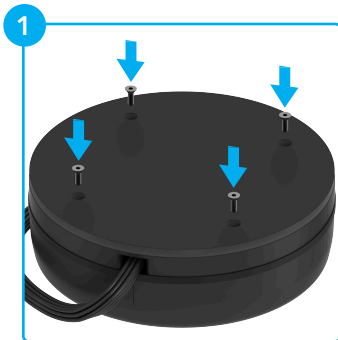

Use the included allen wrench and bolts to **install the magnetic mounting plate** onto OmniRoam.

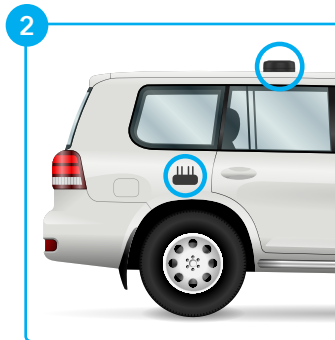

Roughly position your **router inside** the vehicle and **OmniRoam outside** the vehicle.

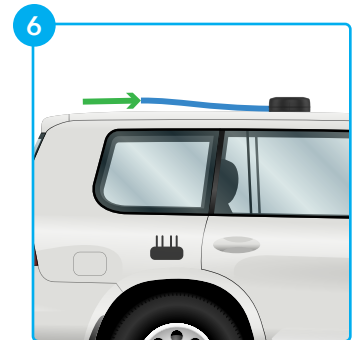

*If your kit includes extension cables, connect them to your OmniRoam now.*

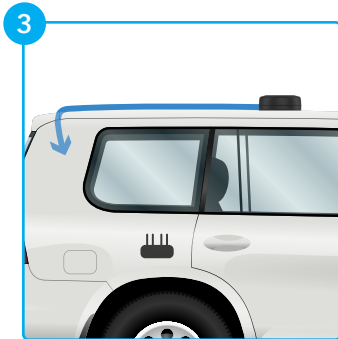

**Route the cables** into the vehicle.

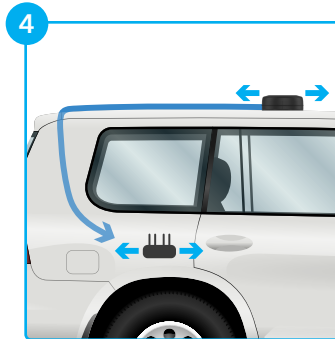

**Adjust OmniRoam and your cellular router** for your cables to reach. Don't connect them yet.

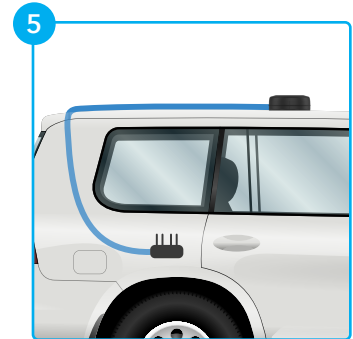

Manage and **secure the cables** inside and outside the vehicle.

## Option 2 Adhesive Mount

If your vehicle's roof is not metal, the adhesive mount is a great way to securely mount OmniRoam:

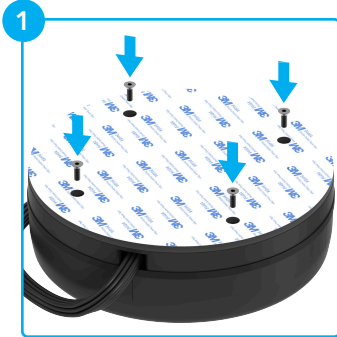

Use the included allen wrench and bolts to **install the adhesive mounting plate** onto OmniRoam.

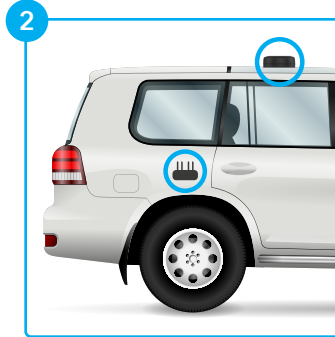

Roughly position your **cellular router** inside the vehicle and **OmniRoam** outside the vehicle.

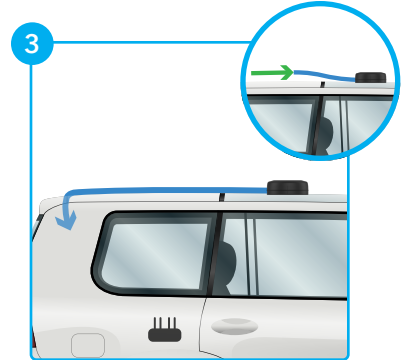

If your kit includes extension cables, **connect them to your OmniRoam** now.  
**Route the cables** into the vehicle.

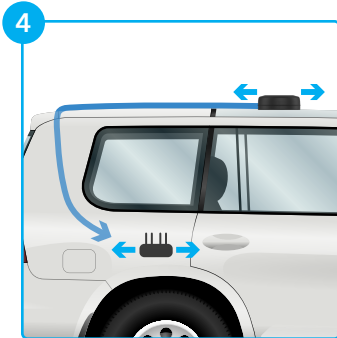

**Adjust the position of your OmniRoam and your cellular router** for your cables to reach. Don't connect them yet.

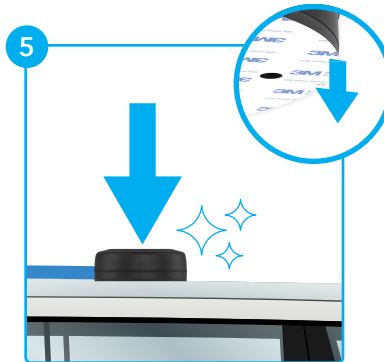

**Clean** the mounting surface thoroughly, **peel off** the adhesive film, and **firmly press** the assembly onto the vehicle for 20 seconds.

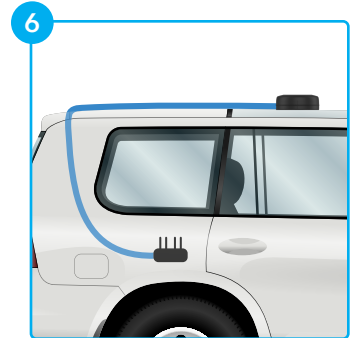

Manage and **secure the cables** inside and outside the vehicle.

## Option 3 Spigot Mount

To permanently install your OmniRoam with the spigot mount, **you'll need the following tools:**

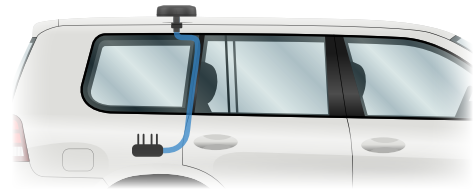

- Drill
- Metal hole saw (1-1/4 in | 32 mm) or Step drillbit (1/8 to 1-1/4 in | 3 to 32 mm)
- Metal pilot drillbit (1/8 in | 3mm)
- Center Punch
- Masking tape

**Don't drill yet!** First, **verify your cables will reach your router** from the mounting point, then follow the steps below to permanently install your OmniRoam directly into the vehicle.

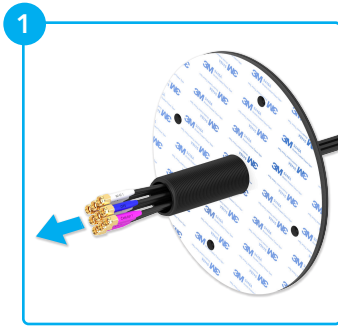

**1** Feed the OmniRoam cables through the spigot mounting plate.

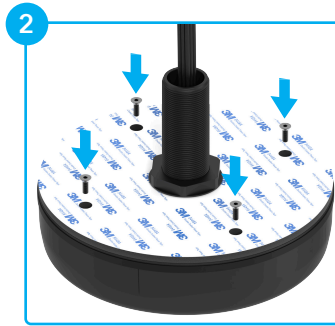

**2** Use the included allen wrench and bolts to **install the spigot mounting plate** onto OmniRoam.

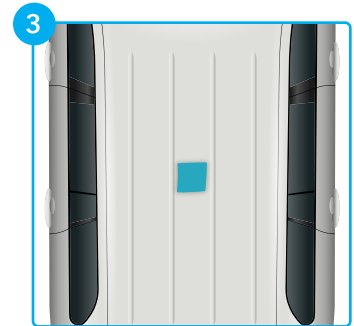

**3** Cover the mounting location with masking tape to **mark the drilling point** and avoid paint damage.

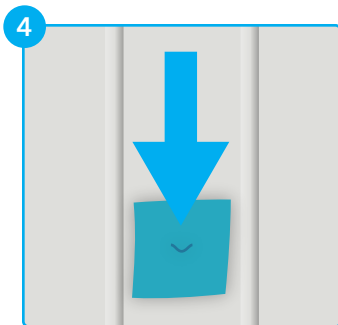

**4** Using a center punch, **make a dimple on your marker** to prevent the drill bit from sliding.

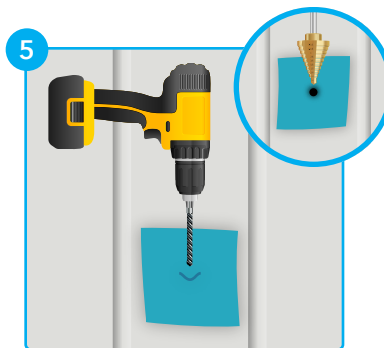

**5** With the drill to a low speed, **drill a pilot hole** into the vehicle. Then, use a hole saw or step drill to **open the hole diameter to 32 mm (1-1/4 in)**.

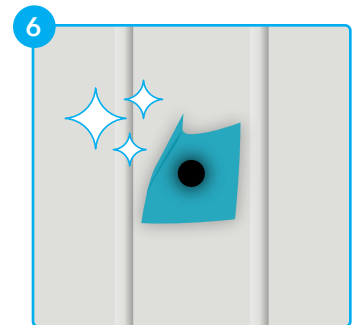

**6** Remove any burrs from the hole, **clean any debris**, and **remove the masking tape**.

## Option 3: Spigot Mount (continued)

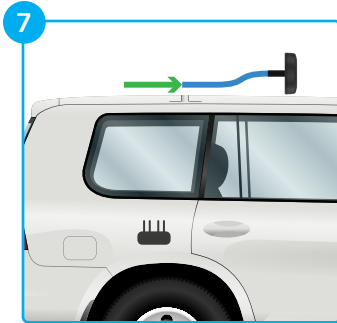

If your kit includes extension cables, connect them to your OmniRoam now.

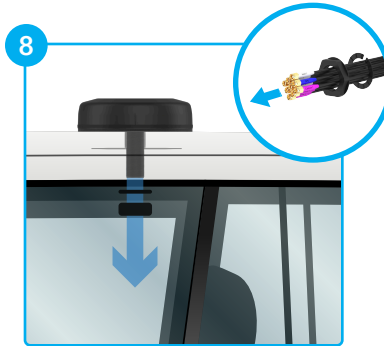

Route the cables into the vehicle and then feed them through the hex nut and washer.

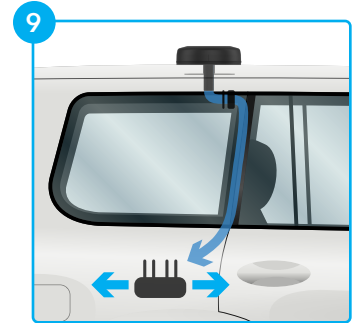

Adjust the position of your cellular router for your cables to reach. Don't connect them yet.

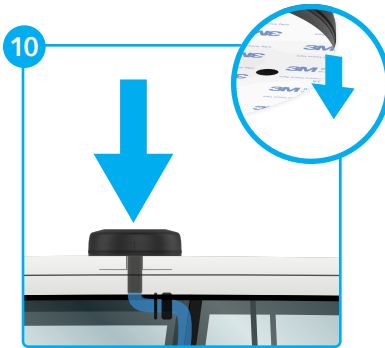

Peel off the adhesive film, and firmly press the assembly onto the hole for 20 seconds.

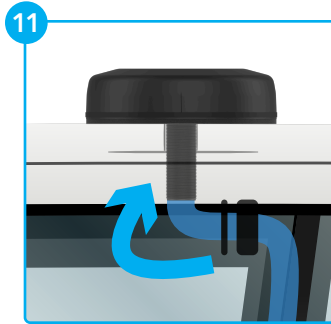

Secure OmniRoam assembly with the washer and hex nut from inside the vehicle.

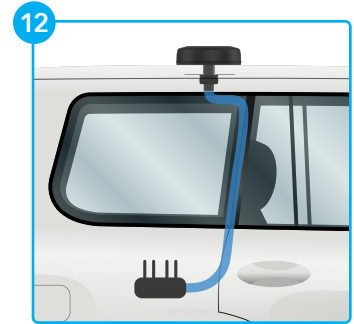

Manage and secure the cables inside and outside the vehicle.

## We're Here to Help!

We know that every use case is different and the steps for mounting your antenna may differ for your unique vehicle. **Don't worry!** If you're running into issues, or have any questions, please reach out.

If you have any questions, or you'd just like a hand, we'd love to help! Call us at **(800) 761-3041**, email [help@waveform.com](mailto:help@waveform.com), or book a meeting at [waveform.com/meet](https://waveform.com/meet) to chat with a dedicated **Waveform Signal Specialist**. We're available from 9am- 5pm PT, Monday to Friday.

# 04 Connecting Your System

Now that you've installed your OmniRoam on your vehicle, **it's time to connect all the components of your system!**

Refer to the diagram below as needed.

- 1** If your cellular router uses TS9 or FAKRA ports for any of its external antennas, **install your adapters** on the relevant cables now.
- 2** **Connect your cables** to your router's antenna ports and hand-tighten. Use the labels indicating the cellular (magenta), WiFi (white) and GPS (blue) cables and connect each to the right port. The order in which you connect the cables to your router doesn't matter.
- 3** **Restart your router**, wait for it to reconnect, then perform 1-2 speed tests to **verify that your system is working correctly**.

*If your OmniRoam has Wi-Fi and/or GPS antennas, test the WiFi and GPS too.*

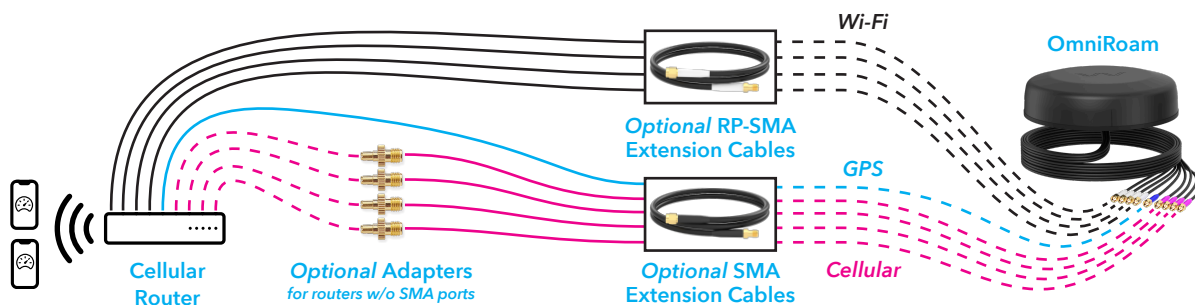

## Install Tips

- **Use cable ties** to securely cable manage any loose antenna cables.
- **A finger-tight connection is sufficient to secure the connectors.** Tools are not required to tighten them and may cause damage.
- **Unsure how your cables connect to your router?** Refer to your router's manual, our device-specific guides at [waveform.com/hotspot-guides](http://waveform.com/hotspot-guides), or reach out to us for assistance.



# Three ways to get money back!

## Get \$30 by sending us a video of your install:

We want to feature videos of our customers who've had success with our kits. Simply email a video (30 sec or more) of your speed test results & how you installed your kit to [videos@waveform.com](mailto:videos@waveform.com) and we'll send you \$30 via Paypal!

## Earn 5% cash back for each friend you refer:

Love your kit? Refer a friend! They'll get 5% off their OmniRoam, and you'll earn 5% (via Paypal) of their purchase. Visit [waveform.com/referrals](http://waveform.com/referrals) to get started.

## Get up to \$1000 for each business you refer:

Know a business with poor cellular signal? Send them our way! If they deploy one of our cellular coverage solutions, you can earn via Paypal:

- **\$250** for spaces between 20,000 and 100,000 sq. ft.
- **\$1,000** for spaces over 100,000 sq. ft.

To get started, simply send an email introduction with your referral to [coverage@waveform.com](mailto:coverage@waveform.com), and we'll handle the rest.



# WAVEFORM

## Need help? We're ready and waiting.

Mobile Antennas, like OmniRoam, aren't always easy to install. But the end result is worth it.

One of the benefits of buying from Waveform is our **lifetime technical support** on every system we sell. We've installed hundreds of these antennas ourselves, and can walk you through troubleshooting and fine-tuning your installation for best results.

Simply give us a call at **+1 (800) 761-3041**, email us at [help@waveform.com](mailto:help@waveform.com), or book a meeting with our fanatical support team at [waveform.com/meet](https://waveform.com/meet)

**We're available from 6am-5pm PT, Monday to Friday.**

We love helping solve tricky install problems.



v1.1.0



Designed by Waveform in the USA



3411 W. Lake Center Dr.,  
Santa Ana, CA 92704



+1 (800) 761-3041



[www.waveform.com](http://www.waveform.com)  
[help@waveform.com](mailto:help@waveform.com)